

## Logic On/Off

### 1- General

This application note describes how to use the On/Off function together with GAIA Converter modules. The logic On/Off function allows the user to inhibit the output of the DC/DC converter using a simple open collector logic

signal and thus avoiding to turn off the DC input bus.

This feature is particularly useful for controlling the output power without having to cycle the input power.

### 2- Implementation

All GAIA Converter DC/DC modules are using the same principle : by pulling the On/Off terminal below 0,2V at 1mA referred to the common terminal will turn off the module.

Two options are possible :

- With mechanical switch
- With logic signals

#### 2-1 Implementation with a Mechanical Switch

A simple mechanical switch can also be used for On/Off operation.

It is recommended to use a minimum-bounce type switch. In addition, when using any type of mechanical switch, GAIA Converter recommends to use a debounce circuit with a resistance and a capacitor.

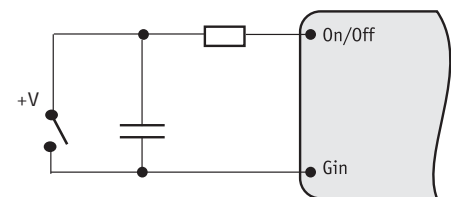

Fig.1 : Typical interface circuit for On/Off operation using mechanical switch

6

#### 2-2 Implementation with a Logic Circuit

A simple open collector logic signal can disable the DC/DC converter. All GAIA Converter DC/DC modules are using the same principle with an open transistor collector command :

- The DC/DC module is on when transistor Q is off or no connection/high impedance.
- The DC/DC module is Off when transistor Q is pulled low.

The logic circuit can be referenced to the primary side of the DC/DC converter or on the secondary side through an opto-isolator

Two options are possible and described in figures on page 2 :

- The On/Off function is referenced to the DC/DC converter primary.
- The On/Off function is referenced to the DC/DC converter secondary.

### 2-2-1 On/Off Function Referenced to Primary

All DC/DC converters have the On/Off function referred to the common input line (Gi) and the typical interface circuit is shown in figure hereafter using a bipolar or MOS transistor. The maximum current pulled in inhibition (Off) is 1mA

To ensure safe turn-off the voltage difference between logic signal and common terminal shall be less than 0,2V at 1mA

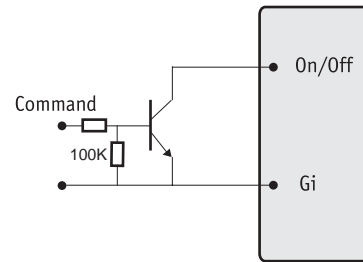

### 2-2-2 On/Off Function Referenced to Secondary.

In some applications, the On/Off function may have to be referenced to the output side of the DC/DC converter. In this case an optocoupleur is recommended as shown in figure 3. The choice of optocoupleur is left to the user.

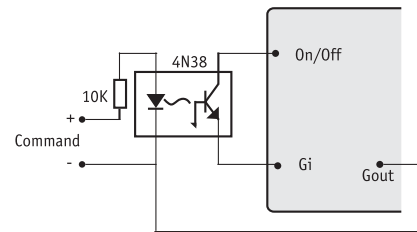

## 3- Logic On/Off with Multiple DC/DC Converters

### 3-1 Logic On/Off with several command transistors

Figure hereafter describes how to implement the On/Off function using multiple DC/DC module . This implementation is valid for 4W, 10W, 18W, 20W, 25W and TETHYS series.

It is not allowed to connect together the different On/Off pins of each converter with only one transistor. Each modules need to have it's own transistor.

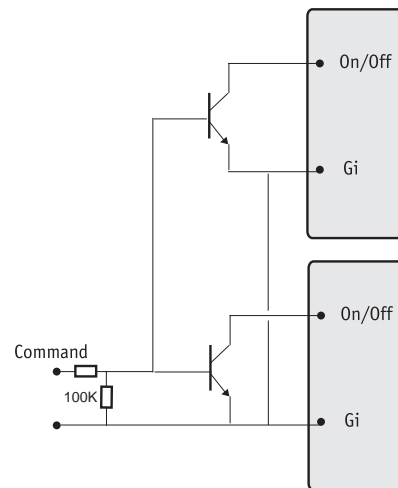

### 3-2 Logic On/Off with one command transistors

Figure hereafter describes how to implement the On/Off function using multiple DC/DC module. This implementation is valid for 26W, 75W 150W series.

A single transistor can be used for multiple modules.

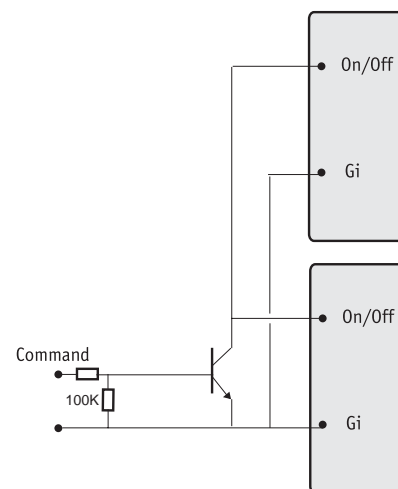

## 5- On/Off function Allocation in GAIA Converter DC/DC module

The On/Off function for GAIA Converter DC/DC modules is generally an option (reference /M to add at the end of the module basic designation) . The following table describes for the different modules the pin allocation.

Module Series	Pin allocation
4W series	Pin 20
10W series	Pin A
18W series	Pin A
20W series	Pin 4
25W series	Pin 4
26W series	Pin 4
35W series	Pin 8
100W series	Pin 1
75W series	Pin 3
150W series	Pin 4

### 5-1 Allocation of On/Off Function on 4 W Series

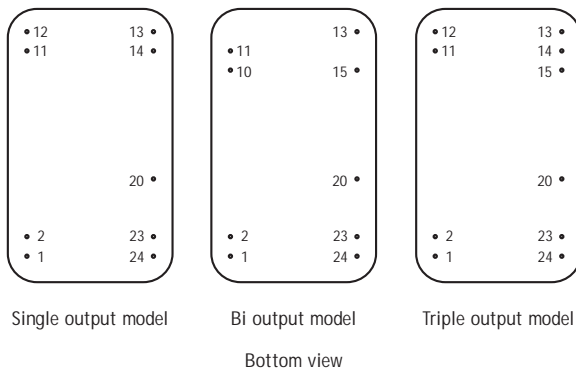

### 5-2 Allocation of On/Off Function on 10 W, 18 W Series

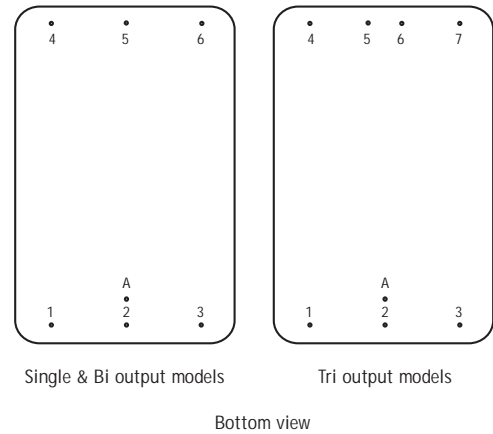

### 5-3 Allocation of On/Off Function on 20 W, 25 W Series

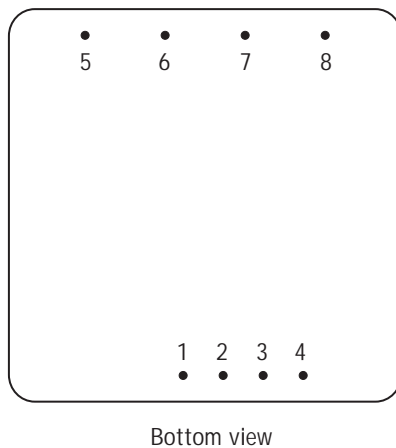

### 5-4 Allocation of On/Off Function on 26 W Series

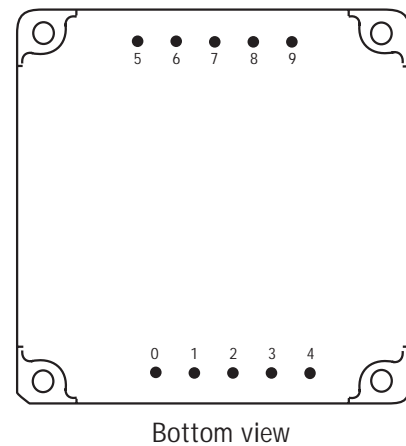

5-5 Allocation of On/Off Function on 35 W Series

5-6 Allocation of On/Off Function on 100 W Series

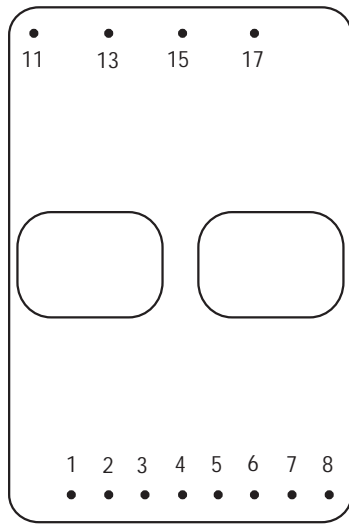

Bottom view

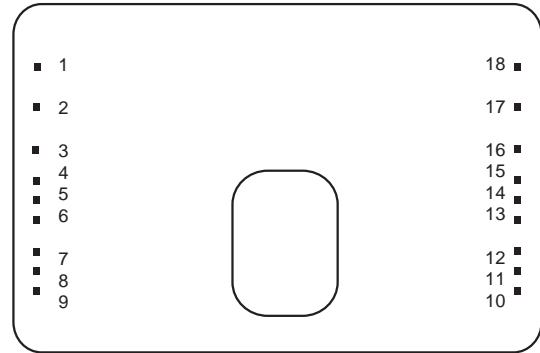

5-7 Allocation of On/Off Function on 75 W Series

5-8 Allocation of On/Off Function on 150 W Series

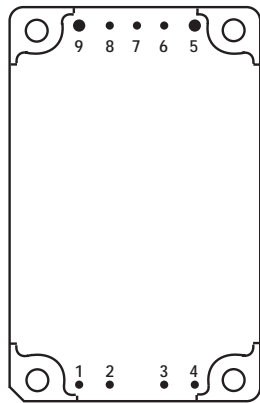

Bottom view

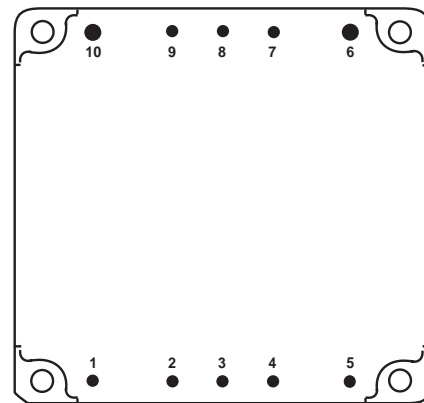

Bottom view



For more detailed specifications and applications information, contact :

**International Headquarters**  
GAIA Converter - France  
ZI de la Morandière  
33185 LE HAILLAN - FRANCE  
Tel. : + (33)-5-57-92-12-80  
Fax : + (33)-5-57-92-12-89

**North American Headquarters**  
GAIA Converter Canada, Inc  
4038 Le Corbusier Blvd  
LAVAL, QUEBEC - CANADA H7L 5R2  
Tel. : (514)-333-3169  
Fax : (514)-333-4519

Represented by :